

SO700153 1/700 IJN 6 m & 8 m Sampans Set

Shelf
Oddity

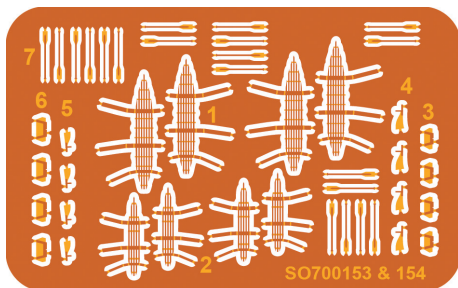

The general view of PE fret.



Resin parts.

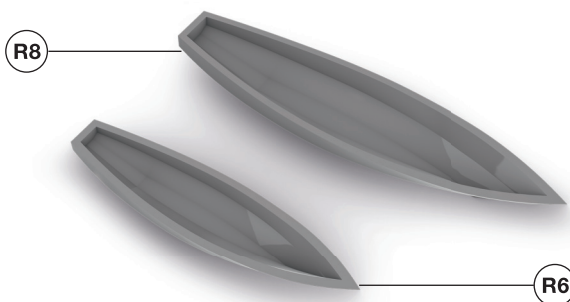

1. Fold grating & benches assemblies.

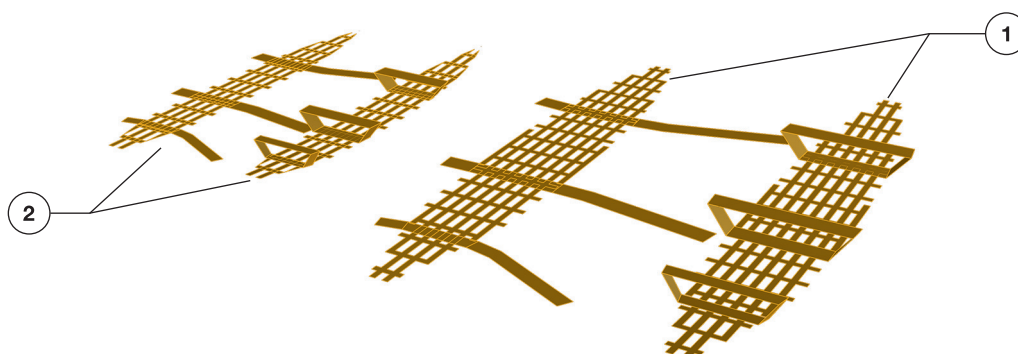

2. Apply already formed gratings/benches and rudders.

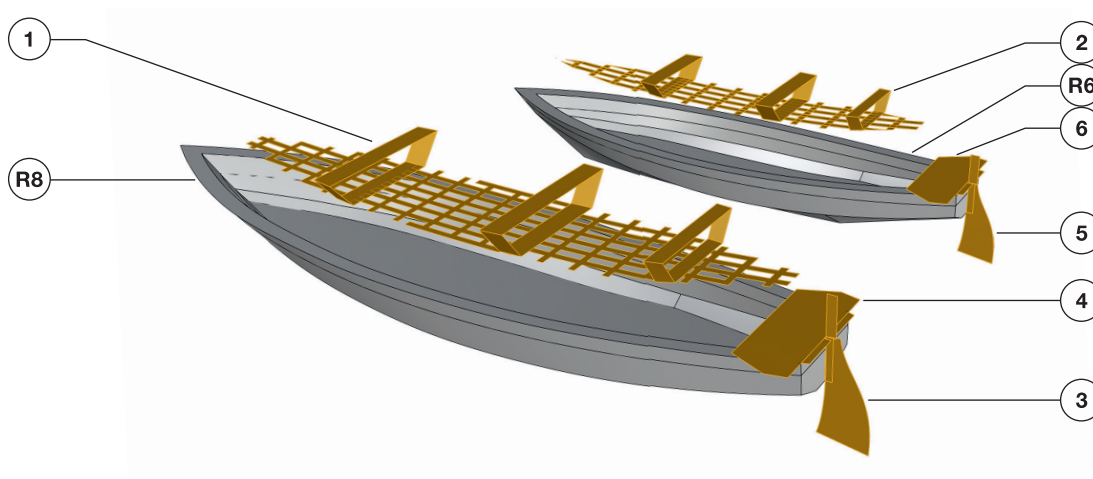



3. The complete sampan assembly.

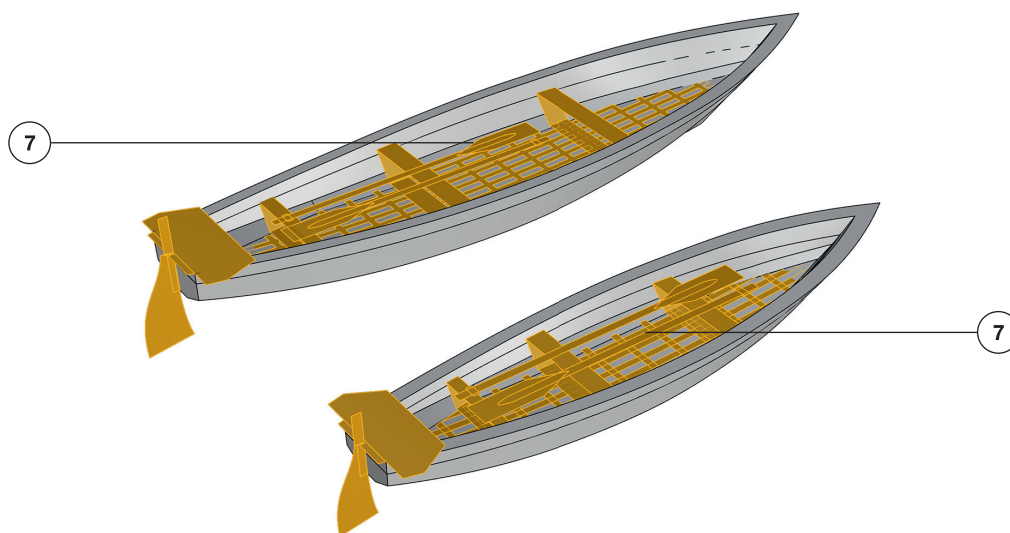

4. Painting & assembly sequence.

A base: Grey

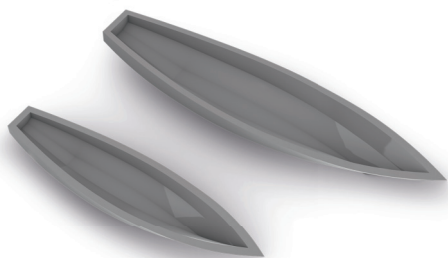

B inside: White

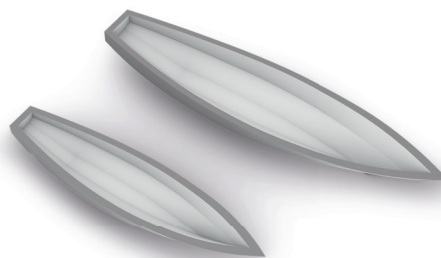

C grating & benches attached: Wood colour

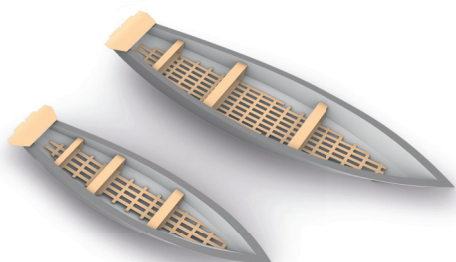

D oars attached: Grey

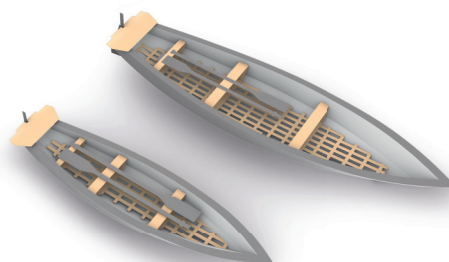



Our products are designed and manufactured in order to achieve the best possible accuracy and real outlook. Manufacturing process may make some minor individual differences among the same items or minor deformations. These can be visible in high zoomed pictures.

General accuracy achieved in our product has reached 0.03 mm.

Due to manufacturing process resin comes as best possible combination of mechanical properties. We have found optimal ratio between mechanical resistance, hardness and elasticity. However resin is fragile. Please take high attention when work with.

Cutting from the waffles

Items are connected to base by supports. Generally support are cylindrical and conical. By using sharp knife cut single support and continue on next one until all become detached.

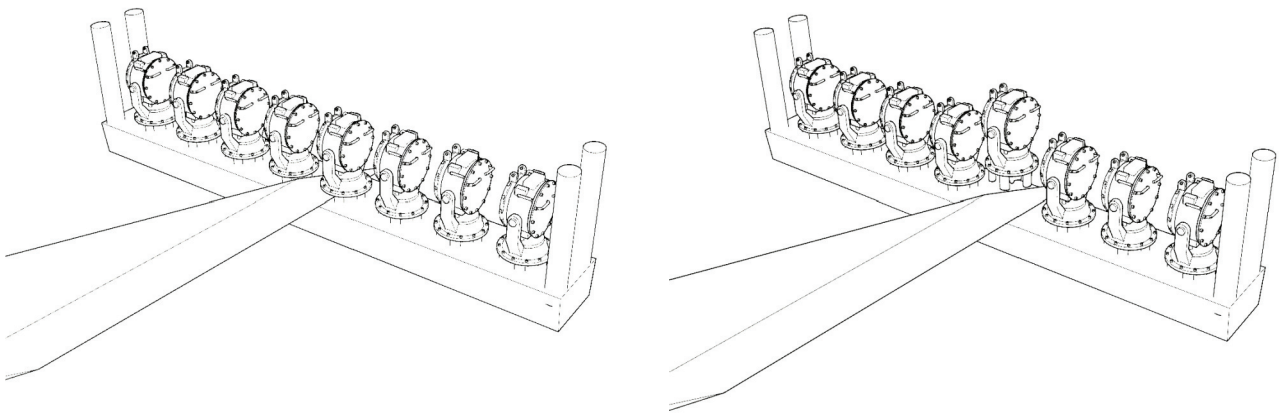

Then remove rest of support to create proper surface.



Drilling holes and material removal

The resin used for these sets is fragile. Using extensive force or aggressive attempts of removing material may lead to breakage of parts. Please pay high attention when selecting the tooling for work with resin. Do not over-apply force while cutting and drilling in resin.

